

Table of Contents

Radio Frequency Energy Notice	2
CE Certification	2
Introduction	4
System requirements & compatibility	4
Summagrid VI overview	4
Drawing area	4
Indicator lights	4
Pointing tools	5
Getting Started	6
Unpacking the tablet	6
Installing the tablet	6
Installing the software	7
Special cases	7
Setting the tablet switch settings	8
Installing the mouse emulation driver	9
Installing the Autodesk ADI driver	12
Customizing the Tablet	13
Learning the Basics	13
Using the pointing tools	13
Learning basic movements	14
Caring for the Tablet	14
Cleaning the tablet	14
Replacing the pen tip	14
Replacing the pen batteries	15
Replacing the cursor batteries	15
Solving Problems	16
Reducing monitor interference	16
Tablet checklist	17
Computer checklist	17
Software checklist	17
Troubleshooting chart	18
Returning your tablet for repair	19
Specifications	19
Parts and Accessories	21
Glossary	22
Warranty for U.S./Canada	25
About Summagrid VI Help	26

Radio Frequency Energy Notice

This equipment has been tested and found to comply with the limits for a Class B digital device, pursuant to part 15 of the FCC Rules. These limits are designed to provide reasonable protection against harmful interference in a residential installation. This equipment generates, uses and can radiate radio frequency energy and, if not installed and used in accordance with the instructions, may cause harmful interference to radio communications. However, there is no guarantee that interference will not occur in a particular installation. If this equipment does cause harmful interference to radio or television reception, which can be determined by turning the equipment off and on, the user is encouraged to try to correct the interference by one or more of the following measures:

- Reorient or relocate the receiving antenna.
- Increase the separation between the equipment and receiver.
- Connect the equipment into an outlet on a circuit different from that to which the receiver is connected.
- Reorient or coil cables.
- If necessary, consult the dealer or an experienced radio/television technician for additional suggestions.

Important: Any cables the user adds to the device must be shielded to be in compliance with the FCC standards. Any unauthorized modification to this device could result in the revocation of the end user's authority to operate this device.

Cordless pen or cursor

This device complies with Part 15 of the FCC rules. Operation is subject to the following two conditions: (1) This device may not cause harmful interference, and (2) This device must accept any interference received, including interference that may cause undesired operation.

Canada

This digital apparatus does not exceed the Class B limits for radio noise emissions from digital apparatus as set out in the radio interference regulations of the Canadian Department of Communications.

Le present appareil numerique n'emet pas bruits radioelectriques dépassant les limites applicables aux appareils numeriques de Classe B prescrites dans le reglement sur le brouillage radioelectrique edicte par le Ministere des Communications du Canada.

Japan

この装置は、第二種情報伝送機（住宅地域又はその隣接した地域において使用されるべき情報伝送機）で住宅地域での電波障害防止を目的とした情報処理装置等電波障害自主規制協議会（VCCI）基準に適合しております。

しかし、本装置をラジオ、テレビジョン受信機に近接してご使用になると、受信障害の原因となることがあります。

取扱説明書に従って正しい取り扱いをして下さい。

CE Certification

Declaration of conformity according to ISO/IEC Guide 22 and EN 45014

Manufacturer's Name: GTCO CalComp, Inc.
Manufacturer's Address: 14555 N. 82nd Street
Scottsdale, Arizona 85260
U.S.A.

declares, that the product

Product Name: Summagrid VI
Model Numbers: SG6-2436, SG6-3648, SG6-4460
Product Options: All

conforms to the following product specifications:

Safety: UL1950, EN 60950:1988+A1+A2

EMC: CISPR22:1985/EN 55022:1988–Class B

EN 50082-1:1992

IEC 801-2:1991–4kV CD, 8kV AD, Criterion B

IEC 801-3:1984–3V/m, Criterion A

IEC 801-4:1988–1kV power lines, .5kV data lines, Criterion B

Supplementary Information

The product herewith complies with the requirements of the Low Voltage Directive 73/23/EEC and the EMC Directive 89/336/EEC.

Scottsdale, Arizona, U.S.A.

6-18-1999

Dana Doubrava

Location

Date

Engineering Manager

European Contact

GTCO CalComp

World Trade Center

A-1300 Vienna – Airport

Austria

Tel + 43 1 7007 36450

Fax + 43 1 7007 36458

Introduction

The **Summagrid VI** is a high performance, low cost digitizer tablet well suited for CAD, mapping, and GIS applications as well as drawing, tracing, and presentation graphics. You can choose from a wide range of options to help you create a working environment suited to your application. The tablets are available in a range of sizes with variable **pointing tool** options.

Topics discussed in this section:

System requirements and compatibility

Summagrid VI overview

System requirements and compatibility

This version of the **Summagrid VI** is equipped with an RS-232 **serial interface**, and is compatible with most industry-standard Personal Computers. The included TabletWorks software provides a WinTab-compliant driver that is compatible with the versions of Microsoft Windows shown below. After installing the PC software, the Summagrid VI will work with all Windows-based applications as a mouse, as well as working with Windows-based applications that are specifically designed to work with digitizers.

Personal Computer requirements

- Microsoft Windows 95, 98, Me, NT 4.0, 2000 or XP
- 1 available serial port
- 10 MB of free disk space
- Installation must be done by a “Power User” or “Administrator” on Windows NT, Windows 2000 and Windows XP.

Summagrid VI overview

The Summagrid VI tablet consists of:

- Drawing area
- Indicator lights
- Pointing tools

Drawing area

The drawing area is the rectangular surface area on the tablet designated by the engraved corners. This is where all your work is performed.

Indicator light

There are two indicator lights within the menu strip: power and configuration. The **power light** turns on when the power is on. It also indicates whether the pointing tool is within range of the drawing area. The power light glows if the pointing tool is inside the drawing area and blinks if it is outside the drawing area.

Pointing tools

There are two types of pointing tools available with Summagrid VI: **pens** and **cursors**.

The pointing tools are available in both corded and cordless versions. The cordless pointing tools are powered by batteries.

Each tool goes into a battery-saving *sleep mode* when no button has been pressed for one to five minutes, depending on the type of tool you are using. To reactivate the tool, press any of its buttons.

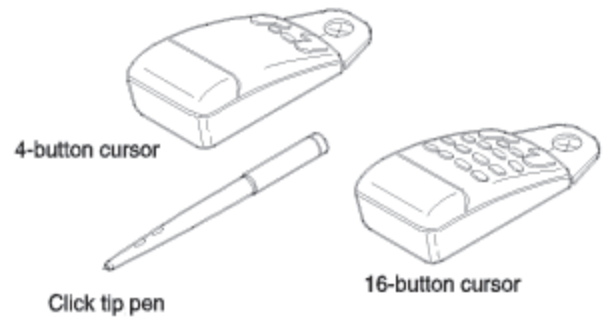

Cursors

The cursor is similar in appearance to a mouse, except that it has an attached lens with crosshairs for highly accurate detail work. Cursors are available with 4 or 16 buttons.

Pens

The pen is similar in appearance to a ball-point pen. It has a button built into the tip plus two side buttons on the barrel.

See [Using the pointing tools](#) for more information.

Getting Started

Getting started with your **Summagrid VI** tablet is fast and easy.

Topics discussed in this section:

Unpacking the tablet

Installing the tablet

Installing the software

Unpacking the tablet

Before you begin installation, verify that you have received everything you ordered. Package contents are listed on the bar code label attached to the box end. In addition to the tablet, the Help file, and this printable Help file, you should have received:

- Pointing Tool (at least one)
- Power Supply
- Software CD with Help files and printable PDF manual
- Registration Card and Quick Start Instructions
- Pen holder (if your pointing tool is a pen)

If any package contents are missing, call GTCO CalComp Customer Assistance at 480-443-2214 in the U.S. or Canada. Outside the U.S. or Canada, please call your local GTCO CalComp office or Summagraphics reseller.

Installing the tablet

All cable connections are made at the rear of the tablet. Turn off your computer and make sure the tablet power switch is in the off position.

1. Connect the serial cable.

Connect the round end of the serial cable to the socket labeled **I/O** on the tablet. The arrow on the connector should face down.

Connect the wide end of the serial cable to the computer's serial communication port. Tighten the thumbscrews. The arrow on the connector should face down.

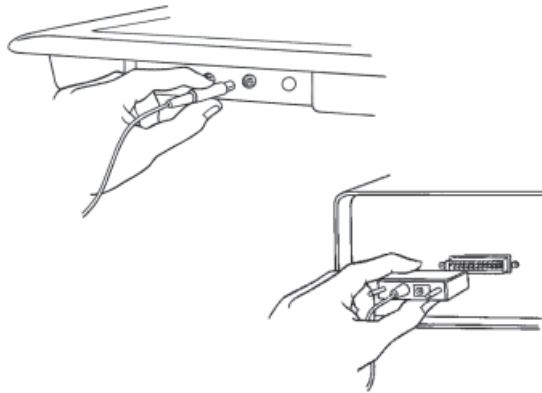

2. Connect the power cable to the serial connector.

Connect the power cable into the jack on the back of the serial cable connector. Connect the power supply end to a power outlet or power strip.

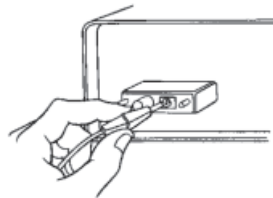

3. Connect the corded pointing tool.

If you are using a corded pointing tool, insert the connector into the socket labeled **POINTER** on the tablet.

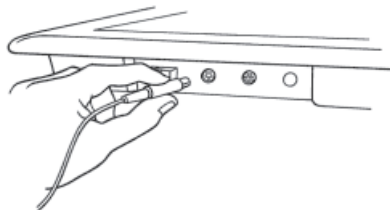

4. Turn on your computer and tablet.

The tablet power switch is located at the rear of the tablet on small format models. On large format models, the switch is located either 1) at the rear of the tablet, or 2) on the left side, near the bottom of the tablet. The power light will turn on.

If you are using a cordless pointing tool, turn it on by pressing any button on the tool. The power light will glow steadily if the pointing tool is inside the drawing area of the tablet. If the pointing tool is outside the drawing area, the power light will blink.

5. Attach the pen holder (optional)

Pens come with a holder that you can mount to your desk, monitor, or anywhere that's convenient. Remove the backing to the adhesive strip on the pen holder, then firmly press the adhesive strip to any surface.

6. Mount the accessory tray

The large format tablets come with an accessory tray that you can mount at any position around the tablet. To mount the accessory tray:

- a Insert the carriage bolts provided into the three tabs on the side of the tray as shown.
- b Loosely attach the black knobs to the bottom of the carriage bolts.
- c Slide the bolts into one of the grooves on the underside of the tablet.
- d Position the tray then tighten the knobs securely.

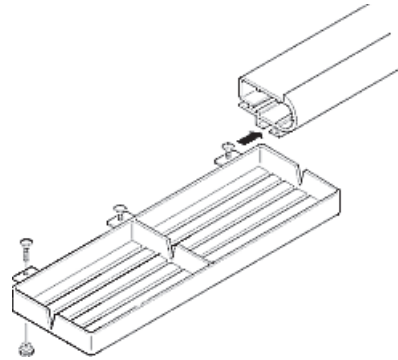

Installing the software

The TabletWorks software included with your Summagrid VI tablet allows you to use your tablet both as a mouse and a digitizer, and to access all tablet features and capabilities through the TabletWorks control panel. Refer to TabletWorks Help for instructions on installing the software and for customizing your tablet.

The TabletWorks software must be installed before any Windows applications (including AutoCAD) will be able to work properly with your Summagrid VI.

Special cases: Setting up the tablet for DOS or other non-Windows environments

If you are using the Summagrid VI tablet with non-Windows applications, you will need to set the tablet switch settings to be compatible with your application. You may also need to install one or both of the following drivers:

■ Mouse emulation driver ([installation instructions](#))

This driver allows you to use the tablet as a mouse in non-Windows applications.

■ Autodesk ADI driver ([installation instructions](#))

This driver allows you to use the tablet with AutoCAD for DOS.

NOTE: If you are using AutoCAD for Windows, you must install the appropriate Windows driver. You will not need the DOS ADI driver.

Setting the tablet switch settings

Summagrid VI provides an easy, interactive way to set the tablet switch settings using the program SG5SETUP found on the TabletWorks CD under the \SGDOSUTL\UTILITY\SG5 directory.

- 1 Insert the TabletWorks CD into the CD drive.
- 2 The Install program should autostart. If it doesn't, type:
D (or appropriate drive letter): **\SGDOSUTL\UTILITY\SG5\SG5SETUP.EXE**
- 3 A screen appears. You can set the switch settings by clicking on the appropriate row/column (see table below). An X will appear which turns the switch *on*, or you can click on the appropriate setting below the matrix, such as Baud Rate, then press the down arrow on the keyboard to see the available settings.
- 4 Click on Change Settings to change the settings for the current work session, or Save Settings to permanently save the settings to the tablet.

Functions		Check (X) these switches
Baud Rate	19200	None
	9600	A1
	4800	A2
	2400	A1,A2
	1200	A3
	600	A1,A3
	300	A2,A3
	150	A1,A2,A3
	Parity	Odd
Even		A4,A5
None		None
Stop bit	1	None
	2	A6
Data bits	7	None
	8	A7
UIOF Formats	Binary	None
	ASCII Counts	A8,B1
	ASCII Units (no decimal)	A8
	ASCII Units (decimal)	A8,B2
GTCO Formats	Binary 23	B6,B8
	Binary 28	B8
	ASCII 9 (no CR)	A8,B8
	ASCII 9(with CR)	A8,B1,B8
	ASCII 10(no CR)	A8,B2,B8
	ASCII 10 (with CR)	A8,B1,B2,B8

Functions		Check (X) these switches
CalComp	Binary 23	B6,B7
	Binary 28	B7
	ASCII 4	A8,B7
	ASCII 5	A8,B1,B7
	ASCII 6	A8,B2,B7
	ASCII 7	A8,B1,B2,B7
MM	Binary	B7,B8
	ASCII	A8,B7,B8
CR	—	None
CR LF	—	B3
Resolution	100 lpi	None
	200 lpi	B5
	1000 lpi	B6
	2000 lpi	B5,B6
	4 lpmm	B4
	10 lpmm	B4,B5
	40 lpmm	B4,B6
80 lpmm	B4,B5,B6	
Operating mode	Prompt	None
	Point	C1
	Track	C2
	Run	C1,C2
Echo	Off	None
	On	C3
Proximity	In	None
	Out	C4
Click	Off	None
	On	C5

Installing the mouse emulation driver

NOTE: If you are using Microsoft Windows, you must install TabletWorks. You will not need the Mouse Emulation Driver.

The TABLETMG drivers are powerful device drivers that provide Microsoft compatible mouse emulation for the Summagrid VI tablet. These drivers are found on the TabletWorks CD under the \SGDOSUTL\DOSDRV\UIOF directory. There are two ways to use the drivers:

- Loading the driver manually
- Loading the driver automatically

Loading the driver manually

The following describes the simplest way to use the TABLETMG driver.

- 1 Insert the TabletWorks CD.
- 2 Copy TABLETMG.COM to your C: drive:
COPY A (or appropriate drive letter): **\SGDOSUTL\DOSDRV\UIOF\TABLETMG.COM C:**
- 3 Run the program by typing at the DOS prompt: **C:TABLETMG.COM**

Loading the driver automatically

To set up your computer to load the tablet driver automatically every time you power on:

- 1 Insert the TabletWorks CD.
- 2 Copy TABLETMG.SYS to your C: drive:
COPY A (or appropriate drive letter): **\SGDOSUTL\DOSDRV\UIOF\TABLETMG.SYS C**
- 3 Using a text editor, add the following line to your CONFIG.SYS file:
DEVICE = C:\TABLETMG.SYS /2 /A

Command line arguments

There are two groups of command line arguments for TABLETMG:

■ Tablet-specific commands

TABLETMG [/#] [/BA####] [/I#] [/C#] [/A or /R] [OFF]

■ Mouse-compatible commands

TABLETMG [/S#] [/H#] [/V#] [/P#] [/M#] [/N#] [/U] [/E] [/HI] [OFF]

	Argument	Description
Tablet-specific	/#	Selects the serial port that the tablet is connected to (1=COM1, 2=COM2, 3 and 4=COM3 and COM4 on PS/2 systems). If this argument is omitted, the driver will be installed on the first serial port where it finds a tablet.
Tablet-specific	/BA#### /I#	If you have an AT-standard COM3 or COM4, or some other 8250 based serial port, then this argument can be used to define the port address, and the /I argument is its IRQ. The BA must be exactly 4 hexadecimal digits. For example: C>TABLETMG /BA03E8 /I4 select port address 3E8 hexadecimal, IRQ4, the AT standard address for COM3.
Tablet-specific	/C#	Selects the pointing tool type that you will be using. The options are: CP = Pen C4 = 4-button cursor C16 = 16-button cursor
Tablet-specific	/CM####	This argument is followed by 0-4 digits that specify which cursor buttons are assigned to act as standard mouse buttons. Each digit represents the number of the cursor button, and its position after the CM represents the mouse button that it is assigned to: /CMlrm where l is the left mouse button, r is the right mouse button, m is the middle mouse button, and b is both left and right mouse buttons pressed simultaneously. For example: C>TABLETMG /CM2134 maps cursor button #2 to the left mouse button, cursor button #1 to the right mouse button, cursor button #3 to the middle button and cursor button #4 to both left and right mouse buttons. If the CM command has no numerical arguments, then the default button mapping for the pointing tool is assumed.
Tablet-specific	/A or /R	Specifies whether the mouse emulation is in absolute or relative mode. If neither is specified, then relative mode is assumed.

Mouse compatible	/S, /H and /V	<p>Three Microsoft mouse driver compatible commands are provided to adjust the sensitivity of the mouse cursor tracking when you have set the emulation mode to relative using the /R option. The default sensitivity setting provides the same tracking response as a 200 dpi mouse, but with the additional smoothness and precision provided by a digitizing tablet. Each sensitivity option has a number from 0 to 100 following it. The default setting is 50. Larger values make the tracking more rapid, smaller values reduce the sensitivity. Experiment to find a comfortable setting. The command options are:</p> <p>/S = Sets both horizontal and vertical sensitivity /H = Sets the horizontal sensitivity /V = Sets the vertical sensitivity</p> <p>For example: C>TABLETMG /S100 makes a very speedy mouse emulation in relative mode. C>>TABLETMG /S10 provides a very slow mouse, great for highly accurate cursor pointing. These command line options can be combined together, and they can also be issued after the driver is initially loaded. For example, you can go back and change the sensitivity of the cursor tracking with the /S command option at any time.</p>
Mouse compatible	/P#	<p>Mouse drivers compatible with mouse version 7.00 and above support a "ballistic gain" feature. As with the sensitivity arguments, ballistic gain only has an effect when you use the TABLETMG driver in relative mode. The TABLETMG driver comes with 4 built-in ballistic gain profiles: slow, moderate, fast, and unaccelerated. To select a ballistic profile, you can use the following options:</p> <p>/P1 = slow /P2 = moderate /P3 = fast /P4 = unaccelerated</p> <p>The default ballistic profile for relative mode is /P2.</p>
Mouse compatible	/M#	<p>The /M option overrides an application that changes the mouse cursor for text modes by "locking" the mouse cursor to the default text cursor:</p> <p>1=enables locked cursor, 2=disables locked cursor (default)</p> <p>This command is compatible with the Microsoft mouse's /M option.</p>
Mouse compatible	/N#	<p>The /N option controls how often the cursor is redrawn as it moves across the screen. This option is useful for systems with LCD displays. A number from 0 to 10 follows that specifies how many screen updates to skip before actually plotting the cursor. The default is 0.</p>
Mouse compatible	/U, /E, /HI	<p>These options allow you to maximize the amount of memory available for DOS application programs. The trick is to move most of the driver to a memory location outside of the 640K area used by most application programs. The /U command moves the driver to the upper memory area between 640K and 1Mb. The /E command moves the driver into expanded memory. The /HI command moves the driver into the high memory area between 1 Mb and 1.064 Mb. Only TABLETMG.COM can be relocated. TABLETMG.SYS cannot be relocated. You cannot relocate the driver into another memory area without first removing the mouse driver by using the OFF command.</p>
Mouse compatible	OFF	<p>Allows you to disable TABLETMG and remove the driver from memory, if possible.</p>

Installing the Autodesk ADI driver

NOTE: If you are using AutoCAD for Windows, you must install the appropriate Windows driver. You will not need the DOS ADI driver.

There are two ADI drivers (For AutoCAD For DOS) available for the Summagrid VI tablet:

■ **DGMG.COM**

This driver allows you to use the Summagrid VI with applications developed by Autodesk. It provides full ADI V4.1 compatibility.

■ **DGPMG.EXP**

This driver is a protected mode ADI driver for Summagrid VI. Use this driver if you have Release 11 or higher 386 DOS extender version of AutoCAD and wish to take advantage of AutoCAD's protected mode capabilities.

You can find both drivers on the CD under the \SGDOSUTL\ADIDRV\UIOF directory.

Installing DGMG.COM

- 1 Insert the CD.
- 2 From within AutoCAD, select the ADI driver option for the digitizer driver. The Summagraphics ADI driver is always installed on Interrupt 79 (hexadecimal), which is the AutoCAD default.
- 3 Load the driver by typing at the DOS prompt: **DGMG [/#] [/C#] [/A#]**.

Argument	Description
/#	Selects the serial port that the tablet is connected to (1=COM1, 2=COM2, 3 and 4=COM3 and COM4 on PS/2 systems). If this argument is omitted, the driver will be installed on the first serial port where it finds a tablet.
/C#	Selects the cursor type that you will be using with the tablet (CP=stylus, C16=16-button cursor).
/A#	Allows digitizing paper drawings in AutoSketch (AC=resetting to the ADI specification, AS=selects AutoSketch digitizing mode). The default mode is the standard AutoCAD mode (AC) which uses the full active area of the tablet. The AutoSketch mode was designed for Autodesk's AutoSketch drawing program. It scales the digitized coordinates from the tablet so that one inch measured on the tablet surface corresponds to one inch measured or plotted by AutoSketch.

Installing DGPMG.EXP for AutoCAD Release 12/13 for DOS

DGPMG.EXP only works with Autodesk products. The following instructions assume that you are installing the driver for use with AutoCAD. If you are using a different Autodesk product, consult the specific product's documentation for details.

- 1 Insert the TabletWorks CD.
- 2 Copy the driver file from the CD to your AutoCAD driver directory without changing the file's name:
COPY A (or appropriate drive letter): \SGDOSUTL\ADIDRV\UIOF\DGPMG.EXP C:\ACAD\DRV
- 3 Start AutoCAD. In the drawing editor, type: **CONFIG**
- 4 At the configuration menu, select *Configure Digitizer*.
- 5 AutoCAD asks you if you want a new digitizer. Type **Y**, and a list of digitizer options appear on the screen.
- 6 Select *Summagraphics Microgrid Series, ADI 4.2 by Summagraphics*.
- 7 Next you are prompted for tablet size, transducer type and COM port number. Enter the appropriate information and when prompted to save changes, enter **Y** to save changes and exit to the drawing editor.

Customizing the Tablet

You can customize your **Summagrid VI** tablet and pointing tool to suit your individual work requirements using TabletWorks. TabletWorks is a Windows program included with the Digitizer Software that helps you use the full capabilities of your tablet. You can map your tablet to the screen area, record your own macros and designate areas on the tablet to switch between open software applications. To learn how to use TabletWorks, please refer to TabletWorks Help.

Learning the Basics

You will find that using your **Summagrid VI** tablet is as easy, or easier, than using a mouse. The Summagrid VI pointing tools are more accurate than a mouse, giving you greater control over your movements.

Topics discussed in this section:

[Using the pointing tools](#)

[Learning basic movements](#)

Using the pointing tools

The pointing tool does not need to be in contact with the tablet surface in order for the tablet to sense its presence. It can be detected up to 1/2" above the drawing area. This allows you to trace through materials placed on the surface, such as a drawing or a book. Also, before using the pointing tool, be sure that sleep mode is turned off by pressing any button on the tool.

For instructions on replacing the batteries for the pointing tools, see [Caring for the tablet](#).

Using the cursor

When you use the cursor, the intersection point of the crosshairs on the lens identifies the point you are selecting. The crosshairs are etched on the bottom of the lens to increase accuracy. For maximum precision, look through the lens from directly over it.

Button 1 on the cursor is used as the pick, or left mouse, button. All other buttons are defined by the TabletWorks software, or through your own software application.

Using the pen

The pen tip is Button 0 and is used as the pick, or left mouse, button. The lower side button is Button 1 and the upper side button is Button 2.

The functions these buttons provide are defined through the TabletWorks software, or through your own software application.

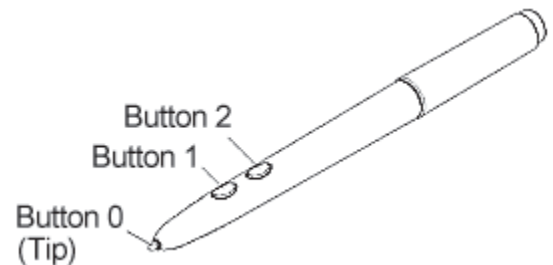

Click tip pen

The click tip pen is available in both corded and cordless versions. It is primarily used for tracing and menu picking. To use the pen, press down until you feel the tip *click*.

Learning basic movements

The **Summagrid VI** pointing tools provide all the basic movements of a mouse. The basic movements are clicking, double-clicking and dragging.

Clicking and double-clicking

Clicking is the action of making a selection. You may be selecting a key on the tablet surface, or making a selection from the monitor screen. To click, place the pointing tool, or move the screen pointer via the pointing tool, to the item to be selected. Tap the pen, or press Button 0 on the cursor. A double-click requires you to tap the pen, or press the button quickly two times while the tool remains in the same place. You can also double-click by pressing the pen, or cursor button that has been defined as a *double-click* button (see TabletWorks Help).

Dragging

Dragging is the action of moving the pointing tool during a selection. To drag, click on an object, but instead of releasing the tip or button, hold it down while moving the pointing tool, or corresponding object on the screen, to the desired new location.

Caring for the Tablet

Follow these precautions at all times to avoid damaging your **Summagrid VI**:

- Avoid discharging static electricity to the tablet.
- Do not place heavy objects on the tablet surface.
- Do not use sharp objects, like compasses or knives, on the tablet surface.
- Do not use the tablet surface for any purpose other than drawing, tracing or digitizing.

Topics discussed in this section:

[Cleaning the tablet](#)

[Replacing the pen tip](#)

[Replacing the pen batteries](#)

[Replacing the cursor batteries](#)

Cleaning the tablet

To clean the tablet's surface, use a soft, non-abrasive cloth. Hardened dirt may be removed with a slightly dampened cloth. Do not clean pencil lines with a soft cleanser or pencil eraser. This may create an undesirable shiny spot on the tablet's surface that cannot be removed.

Warning: Do not use abrasive cleaners, acrylic or lacquer paint thinners, or cleansers with an acetone or solvent base, such as MDC or EDC, on the tablet surface. They will damage the tablet case.

Replacing the pen tip

To replace the pen tip, grasp the tip and pull straight out (see figure). Insert the new tip and press until it clicks into place.

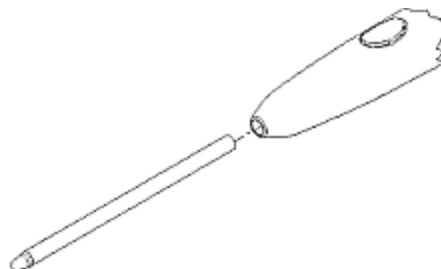

Replacing the pen batteries

The pens require two 393 silver oxide batteries. The average battery life is 750 to 1,000 hours.

Warning: Do not use ZINC AIR batteries as replacement batteries. They will corrode the electronics of the pen.

To replace the batteries:

- 1 Unscrew the pen cap. Hold the pen from the bottom and gently slide off the pen cover to expose the batteries.
- 2 Remove the old batteries by turning the pen over and gently tapping it, letting the batteries fall into your other hand.
- 3 Insert the new batteries as they are shown in the graphic (“+” towards pen tip).
- 4 Replace the pen cover, then screw the pen cap onto the pen.

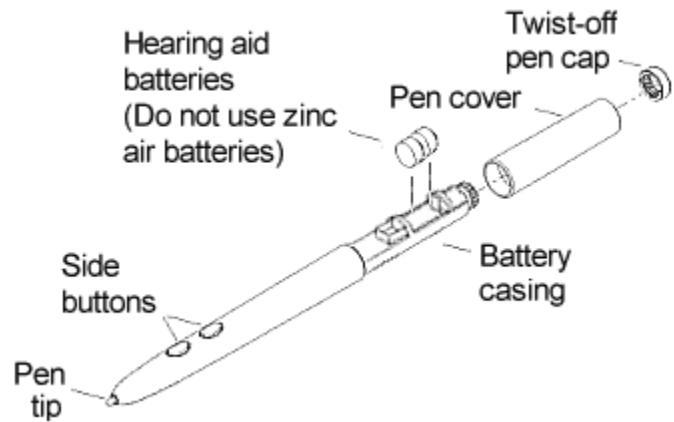

Note: When you replace the pen batteries, the pen will reset to the default frequency. If you changed the frequency of the pen before replacing the batteries, you will need to do so again after replacing the batteries (see the [Reducing Monitor Interference](#) section in [Solving Problems](#)).

Replacing the cursor batteries

The cursor requires two AAA batteries. The average battery life for the cursor batteries is 4,000 hours.

To replace the batteries:

- 1 Place the cursor face down in the palm of your hand. Use a Phillips screwdriver to remove the two screws located on the bottom of the cursor (see figure). Remove the cursor base.
- 2 Remove the old batteries from the battery casings.
- 3 Place the new batteries in the casings, matching the polarity of each battery with the markings on the connector strips (match + to +).
- 4 Reposition the cursor base. Replace the screws with the Phillips screwdriver.

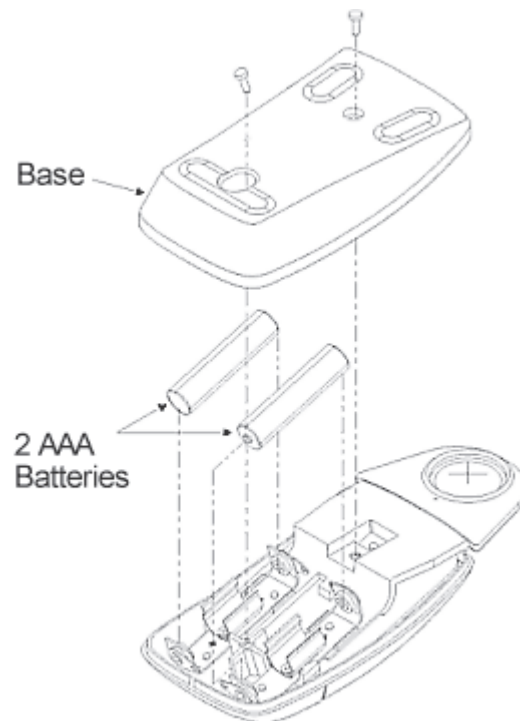

Note: When you replace the cursor batteries, the cursor will reset to the default frequency. If you changed the frequency of the cursor before replacing the batteries, you will need to do so again after replacing the batteries (see the [Reducing Monitor Interference](#) section in [Solving Problems](#)).

Solving Problems

We want your experience with your **Summagrid VI** tablet to be a successful one. If you have a problem, please follow the steps below.

- 1 Reread Summagrid VI Help to verify you have performed the correct steps.
- 2 Read the topics below to check for a solution to your problem. Review the checklists as well as the troubleshooting chart. Keep in mind that the problem may be your computer, your display or your software, instead of the tablet.

Topics discussed in this section:

[Reducing monitor interference](#) (changing the frequency of pointing tools)

[Tablet checklist](#)

[Computer checklist](#)

[Software checklist](#)

[Troubleshooting chart](#)

[Returning your tablet for repair](#)

- 3 If you still have a problem, call GTCO CalComp Technical Support at 480-443-2214 (in the U.S. or Canada), or fax us at 480-948-5508. Outside the U.S. or Canada, contact your local GTCO CalComp office or dealer. Please have the following information available before you call:
 - Description of the problem
 - Name and version of software package you are using
 - Type of computer you are using
 - Summagrid VI model number and serial number (see bottom of tablet)
 - Type of pointing tool you are using
- 4 Be at your computer when you call.

Reducing monitor interference

If you are experiencing monitor interference with your tablet, you can reduce the interference by changing the frequency your tool uses. Pointing tools with the following FCC ID numbers support two frequencies: ECPPPP, ECPPP2, ECPPLTP, ECPPCURSOR4, ECPPCURSOR16, and ESPPCURSORII. Pointing tools with FCC ID numbers other than those listed must have frequencies changed at GTCO CalComp.

Changing the frequency of the cordless cursor

- 1 Place the cursor on the tablet surface.
- 2 Press Buttons 1 and 2 simultaneously and hold for approximately three seconds.
- 3 The cursor turns itself off. You will know the cursor is off when the power light on the tablet begins blinking.
- 4 The cursor turns on again at the new frequency. You will know the cursor is on when the power light glows steadily.

To return to the default frequency, repeat the above process. When you replace the cursor batteries, the cursor is automatically reset to the default frequency.

Changing the frequency of the cordless pen

Press both side buttons and the tip simultaneously and hold for approximately three seconds.

To return to the default frequency, repeat the above process. When you replace the pen batteries, the pen resets to the default frequency.

Tablet checklist

- Is the tablet power supply plugged into the serial connector and into a live outlet?
- Is the tablet power switch on?
- Does the power light glow steadily when the pointing tool is inside the drawing area? Does it blink when the pointing tool is outside the drawing area?
- The power light will blink if the pointing tool has gone into sleep mode. Press any button on the tool to activate it. If the power light continues to blink and the pointing tool is in the drawing area, change the pointing tool's battery.
- Are all cable connections tight?
- Power cable to serial connector?
- Pointer cable to tablet?
- Serial cable to tablet?
- Serial cable to computer? Check that the cable is connected to the serial port specified in your software package.
- Is the tablet set up according to the software recommendations?
- Are any of the connector cables or receptacles damaged? Check for bent pins, cut insulation, and loose wires.

Computer checklist

- Is the computer plugged into a live outlet? Did you turn on the computer?
- Does the computer work with any software? Try one of your other programs. If the computer has a diagnostic diskette, use it.
- Is your software package installed correctly?
- Does the serial port work? The only way to test the port without special equipment is to reinstall something that has worked in the past and test if it still works.
- Have there been any recent electrical storms in your area that may have damaged your equipment?

Software checklist

Does the tablet work with some software?

If your tablet currently works with some software packages, you know that the tablet, serial port, and computer work.

- Even if the software package you are trying to install and the software that is working both support the same tablets, it does not always mean that you can use the same tablet settings. The output format may be the same, but the communications protocol, resolution, operating mode, and data rate may be different. Check your software's requirements.
- Call the software manufacturer. Perhaps the software package has a problem with another component of your system.

Did the software work in the past?

If the software package worked with the tablet in the past, then the problem lies with the new setup.

- ❑ Check all the connectors. Is the tablet still plugged into the same port? If yes, reset the tablet by unplugging and replugging the power supply and restart the software.
- ❑ Did you reset or power down the computer?
- ❑ During reset and power on the computer can send meaningless characters out the serial port and this can disable the tablet. Reset the tablet again.
- ❑ Have you installed any new software or hardware? Remove it from your system and see if the problem goes away.
- ❑ Did you move any cables?
- ❑ If you are using a PC, did the new software alter your AUTOEXEC.BAT file?
- ❑ Have you updated the software or its drivers?
- ❑ Are you loading another mouse driver?
- ❑ Did you reinstall the software, perhaps after a problem with your hard drive? Double check your installation procedure and the driver you selected.
- ❑ Reinstall the software from its master diskettes. The program files may have been corrupted.

Troubleshooting chart

The following table lists common Summagrid VI problems, their causes and their solutions.

Problem	Cause	Solution
Frozen screen pointer	Pointing tool is in "sleep" mode.	Press any button on the tool.
	Tablet plugged into the wrong serial port on the computer.	Check that the serial port used is correctly identified in your software application.
	Tablet not powered correctly.	Check that the power cable is installed correctly.
	Batteries low in pointing tool.	Replace the batteries in the pointing tool.
	Software application set up incorrectly.	Check that the tablet is identified in your software application.
Screen pointer appears to shake or jitter	Another device is connected to a COM port that shares the same IRQ as the tablet COM port (<i>i.e.</i> , your tablet is connected to COM1 IRQ4 and your modem is connected to COM3 IRQ4).	Move one of the devices to another COM port. Contact your system manufacturer for assistance in relocating the device.
	Tablet is set too close to the screen monitor.	Move the tablet farther away from the screen.
Unable to use the entire tablet surface	Tablet's frequency setting may conflict with the display.	Alternate the pointing tool's frequency. (See the Reducing monitor frequency section earlier in this chapter.)
	Incorrect format selected.	Check your selections in the menu strip.
	Software application set up incorrectly.	Check that the tablet is identified in your software application.

Returning your tablet for repair

If you think you have a defective tablet, first see all topics in this section (above) and visit our Web site at www.gtcocalcomp.com/calcompproducts/a_station/default.htm for the latest support information.

If you are still unable to properly operate your digitizer system, call Technical Support at 480-443-2214, or e-mail us at calcomp.support@gtcocalcomp.com. Technical Support will assist you in determining if your tablet is defective, and will help you obtain a Return Merchandise Authorization (RMA) number. **Important:** Please do not return your product without first discussing the problem with, and receiving an RMA from, a GTCO CalComp Technical Support Specialist.

Repackaging for shipment

Whenever you ship electronic equipment, try to ship it in its original packing materials. Because packing materials are static-charged, you should ship the cursor or any extra electronics boards inside approved anti-static plastic bags. If you are shipping the tablet or accessories to a GTCO CalComp Service Center for repair, attach a tag to the equipment with the following information:

- Model number
- Serial number
- Maintenance contract number (if applicable)
- Return Merchandise Authorization number
- Detailed description of the problem

Specifications

The following tables list **Summagrid VI** technical specifications:

Topics discussed in this section:

Communications specifications

Design specifications

Electrical specifications

Regulatory specifications

Environmental specifications

Physical specifications

Communications specifications

The **Summagrid VI** tablet uses asynchronous **serial RS-232C transmission** with RS-232C/CCITT V.24 signals. The host end of the cable is standard.

Design specifications

FeatureDescription

Resolution	Variable up to 2,540 lpi, 100 lpmm
Accuracy	± .010" standard accuracy ± .005" high accuracy
Proximity	>.5" (12 mm)
Jitter	± 1 lsb
Repeatability	.001"
Maximum Data Rate	>200 pps (corded) >170 pps (cordless)

Electrical specifications

FeatureDescription

Power Source	Wall mount power supply with a 2.1mm monoplug DC connector and positive outside diameter
Input Voltage	12 to 17 VDC
Current Draw	400 ma

Regulatory specifications

Feature	Description
Safety	UL1950, EN60950
Electromagnetic/Immunity	FCC Class B, DOC Class B, VCCI Class II, EN50082-1

Environmental specifications

Feature	Description
Operating Temperature	50° to 104°F (10° to 40°C)
Storage Temperature	-40° to 158°F (-40° to 70°C)
Humidity Range	0% to 95%, non-condensing
Operating Altitude	Up to 15,000 ft. (4,572m) above sea level
Storage Altitude	Up to 50,000 ft. (15,244m) above sea level

Physical specifications

Model	Active Area	Footprint	Weight	Shipping Wt (Avg)
SG6-2436	24 in x 36 in (610 mm x 914 mm)	32.5 in x 46 in (826 mm x 1168 mm)	25 lb (11.4 kg)	45 lb (20.4 kg)
SG6-3648	36 in x 48 in (914 mm x 1219 mm)	44.5 in x 60 in (1130 mm x 1524 mm)	40 lb (18.2 kg)	71 lb (32.2 kg)
SG6-4460	44 in x 60 in (1117 mm x 1524 mm)	52.5 in x 69 in (1333 mm x 1753 mm)	69 lb (31.3 kg)	93 lb (42.1kg)

Parts and Accessories

The following table lists the **Summagrid VI** systems and parts available for purchase. To order any of the items listed below, please contact GTCO CalComp at 1-800-458-5888 (Toll Free), or 480-443-2480, fax to 480-443-2284, email to calcomp.sales@gtcocalcomp.com, or visit us on-line at www.gtcocalcomp.com.

Tablets	Model	Description
	SG6-2436	24 x 36" active area
	SG6-3648	36 x 48" active area
	SG6-4460	44 x 60" active area

Pointing Tools	Description
	4-button cursor, corded
	4-button cursor, cordless
	16-button cursor, corded
	16-button cursor, cordless
	Two-side button/click tip pen, corded
	Two-side button/click tip pen, cordless

Accessories	Description
	Accessory tray
	Power supply, 100/110V
	Power supply, 220/240V
	I/O cable with 9-pin connector
	9- to 25-pin adapter
	Six hearing aid type batteries for pens
	Replacement tips for pen (3 pack)

Glossary

Accuracy

The similarity of a distance measured by the tablet with the actual distance. When we specify that the accuracy of a tablet is $\pm .010$ inches, we mean that every point in the drawing area is within .010 inches of where it should be.

ASCII

Abbreviation for American Standard Code for Information Interchange.

Baud rate

The rate of speed that data flows between a host computer and the digitizer. It is the number of bits transmitted per second. The lower the baud rate, the slower the speed.

Bit

The basic unit of information in the binary system—either 0 or 1.

Button

A switch on the cursor or pen used to input data.

Byte

A group of eight bits that acts as a single unit of information.

Coordinate pair

A pair of numbers representing a unique point on the digitizer surface, usually the distance across and up from the tablet origin.

CR

The ASCII carriage return character usually added to the end of the X,Y coordinate pairs sent by the tablet (ASCII formats).

Cursor

1) A pointing tool used to select specific points on the tablet surface. 2) A symbol displayed on the screen marking where the next action will take effect or where the next character typed from the keyboard will appear.

Data bits

Each transmission contains 7 or 8 data bits.

Data rate

The number of coordinate pairs (X,Y) the tablet sends to the computer per second.

Default

A value, action or setting that a computer system assumes unless the user gives an explicit instruction to the contrary.

Drawing area

The area on the tablet surface intended for digitizing.

Format

The form in which data is sent from the tablet. The Summagrid VI tablet can output 32 different formats.

Frequency

The number of waves that pass a fixed point in one second.

Height

See Proximity.

Increment modes

This mode is used with other operating modes. Data points are sent only if the pointing tool has moved the required increment distance in either the X or Y direction and has satisfied the requirements of the operating mode. These increment distances are set separately for each axis.

Jitter

A repeatability error of short duration caused by electrical noise.

Key

A portion of the tablet surface available to the user for tablet setup.

Line feed

Optional character added to the end of an output format that causes the printer to move to the next line, or causes a line to be added on the display screen.

Line mode

The tablet sends coordinate data points continuously, while the pen tip or a cursor button is depressed, and one additional point when the pen tip or cursor button is released.

LPI

Abbreviation for line per inch. English unit of measurement for resolution measuring the number of separate, distinguishable locations that may be found within the distance of one inch.

LPmm

Abbreviation for lines per millimeter. Metric unit of measurement for resolution measuring the number of separate, distinguishable locations that may be found within the distance of one millimeter.

Operating mode

The conditions that must be met before the tablet sends information to the computer.

Output format

The system of characters used by the tablet for outputting data.

Parity

A type of error detection where a bit is inserted into every character the digitizer transmits. The status of the parity bit confirms that the data was not altered during transmission.

Point mode

The digitizer transmits one coordinate data point when a cursor button or the pen tip is depressed.

Pointing tool

The tool used to digitize; it may be either a cursor or pen.

Prompt mode (Remote)

The digitizer transmits one coordinate pair each time the computer sends a prompt character to the unit. Prompting can operate with any mode, except Mouse mode.

Proximity

The greatest distance above the drawing area that the pointing tool can be raised and still be sensed by the tablet.

RAM

Abbreviation for Random Access Memory, a specific type of memory used by the computer.

Resolution

The distance increment that the tablet outputs in lines/inch or lines/mm.

ROM

Abbreviation for Read Only Memory, a specific type of memory used by the computer.

Run mode (Stream)

The digitizer transmits coordinate data points continuously, regardless of the status of the cursor buttons or the pen

tip. This mode is also called *Stream* by some manufacturers.

Serial transmission

Data transmission protocol where each bit of the data character is sent one at a time over a single circuit. This system saves on transmission circuitry, but is usually slower than parallel transmission.

Stop bits

One or two stop bits are transmitted with each data byte. They mark a completed transmission.

Track mode (Switched Stream)

The digitizer transmits coordinate data points continuously, but only while the cursor button or pen tip is depressed. This mode is also called *Switch Stream* by some manufacturers.

X direction

The horizontal direction across the face of the tablet.

Y direction

The vertical distance up and down the face of the tablet.

Warranty for the United States and Canada

GTCO CalComp warrants to the original end user (as evidenced by a copy of the receipt and registration card that has been returned to GTCO CalComp within thirty (30) days of purchase date) that the product will be free from defects in materials and workmanship for a period of twelve (12) months from the date of purchase by the end user. GTCO CalComp, in its sole discretion, may either repair or replace the defective product. Cursors, pens, options, cables, power supplies, upgrade and accessory items are also covered by a twelve (12) month warranty.

All warranty service will be performed at the GTCO CalComp digitizer factory. The purchaser is encouraged to visit the Company's web site (www.gtcocalcomp.com) where current driver releases as well as comprehensive technical support, troubleshooting and FAQs can be found. The purchaser is required to call GTCO CalComp's Technical Support and Service Department at (480) 443-2214 for CalComp and Summagraphics brand products and (410) 312-9221 for GTCO and Science Accessories brand products to receive a Returned Material Authorization (RMA) number prior to returning any product thought to be defective. Purchaser is responsible for freight charges to the GTCO CalComp factory under this warranty.

A nominal warranty processing and handling fee will be charged after the first 90 days of use, calculated from the date of purchase by the original owner. This payment must be made by Credit Card prior to issuance of the RMA.

This warranty only applies to equipment purchased in the United States and Canada. For equipment purchased outside of the United States and Canada contact your local dealer or distributor.

This warranty does not cover: (1) consumable parts (*i.e.*, batteries, pen tips, etc.); (2) products with serial numbers that cannot be read; (3) products which have been operated with incompatible consumable parts or accessories. Warranty will not cover damage resulting from: (1) abnormal conditions including but not limited to accidents, fire, water, etc.; (2) neglect or misuse of the product; (3) causes external to the product including but not limited to failure or fluctuation of electrical power, air conditioning, humidity control, etc.; (4) maintenance, repairs, alterations, or modifications performed by any person or entity other than GTCO CalComp.

THE FOREGOING EXPRESS WARRANTIES ARE EXCLUSIVE AND ARE IN LIEU OF ANY OTHER WARRANTIES OR REMEDIES, EXPRESS, IMPLIED OR STATUTORY, INCLUDING THE IMPLIED WARRANTIES OF MERCHANTABILITY AND FITNESS FOR A PARTICULAR PURPOSE. GTCO CALCOMP SHALL IN NO EVENT BE LIABLE TO BUYER OR ANY THIRD PARTY FOR ANY CONSEQUENTIAL, INDIRECT, SPECIAL OR INCIDENTAL DAMAGES. IN NO EVENT SHALL GTCO CALCOMP'S LIABILITY EXCEED THE ORIGINAL PURCHASE PRICE OF THE PRODUCT, EVEN IF ADVISED OF THE POSSIBILITY OF SUCH DAMAGES. GTCO CALCOMP SHALL NOT BE LIABLE BECAUSE THE PRODUCTS OR ANY DEFECTS THEREIN CAUSED ANY DAMAGE TO OR FAILURE OF OTHER EQUIPMENT TO WHICH THE PRODUCTS ARE CONNECTED.

GTCO CALCOMP DISCLAIMS ANY LIABILITY FOR FAILURE OF THE PRODUCT TO CONFORM TO ANY AND ALL SPECIFICATIONS, INCLUDING, BUT NOT LIMITED TO, DRAWINGS, MODELS AND SAMPLES OF THE PRODUCT THAT WERE USED IN CONNECTION WITH THE SALE OF THE PRODUCT.

SOME STATES DO NOT ALLOW FOR THE EXCLUSION OR LIMITATION OF CERTAIN LIABILITIES, SO THE ABOVE LIMITATION MAY NOT APPLY. THIS WARRANTY GIVES YOU SPECIFIC LEGAL RIGHTS, AND YOU MAY ALSO HAVE OTHER LEGAL RIGHTS WHICH VARY FROM STATE TO STATE. FURTHERMORE, THIS WARRANTY MAY VARY IN OTHER COUNTRIES WHERE THE PRODUCT IS SOLD OR DISTRIBUTED.

About Summagrid VI Help

Part Number 53-00080 Rev. B

© 2003 GTCO CalComp, Inc. All rights reserved. No part of this publication may be reproduced, stored in a retrieval system, or transmitted, in any form or by any means, electronic, mechanical, photocopying, recording or otherwise, without the prior written permission of GTCO CalComp, Inc.

Summagrid VI is a trademark and Summagraphics is a registered trademark of GTCO CalComp, Inc. AutoCAD is a trademark of Autodesk, Inc. GTCO and MD7 are trademarks and DigiPad is a registered trademark of GTCO CalComp, Inc. IBM is a registered trademark of International Business Machines Corp. Microsoft and Microsoft Windows are registered trademarks of Microsoft Corp. SummaSketch, Bitpad 1, Bitpad 2, and Series MM are trademarks and Summagraphics is a registered trademark of Summagraphics Corp.